

DATSUN 280ZX Model S130 Series



SECTION ST

STEERING SYSTEM

CONTENTS

STEERING COLUMN AND GEAR	ST- 2	SERVICE DATA AND SPECIFICATIONS	ST-21
STEERING WHEEL	ST- 2	GENERAL SPECIFICATIONS	ST-21
STEERING COLUMN	ST- 3	INSPECTION AND ADJUSTMENT	ST-21
STEERING LOCK	ST- 4	TIGHTENING TORQUE	ST-22
MANUAL STEERING GEAR (R.P. 15L) AND LINKAGE	ST- 5	TROUBLE DIAGNOSES AND CORRECTIONS	ST-23
POWER STEERING GEAR (I.P.S. 56L) AND OIL PUMP	ST-10	SPECIAL SERVICE TOOLS	ST-24
STEERING LINKAGE (Equipped with I. P. S. 56L)	ST-19		

CAUTION:

1. Never use any force which could damage the steering column or other parts.

2. When inspecting or adjusting the steering system, the vehicle should be on a level surface.

3. After inspecting or adjusting the steering system, the vehicle should be driven on a road to check the steering operation.

REMOVAL

1. I.P.S. model

Remove the steering column nut and washer.

CAUTION:

Do not take out of steering column shaft with a hammer. Doing that will damage bearing or column shaft.

INSTALLATION

1. Apply grease to fitting surfaces.

2. Install steering wheel on column shaft in the direction of arrow.

3. Tighten steering wheel nut on column shaft in the direction of arrow.

REMOVAL

1. Disconnect battery ground cable.

2. Remove horn pad.

3. Remove steering wheel nut.

4. Remove steering wheel using a Wheel Puller (ST-18000).



ST

STEERING COLUMN AND GEAR

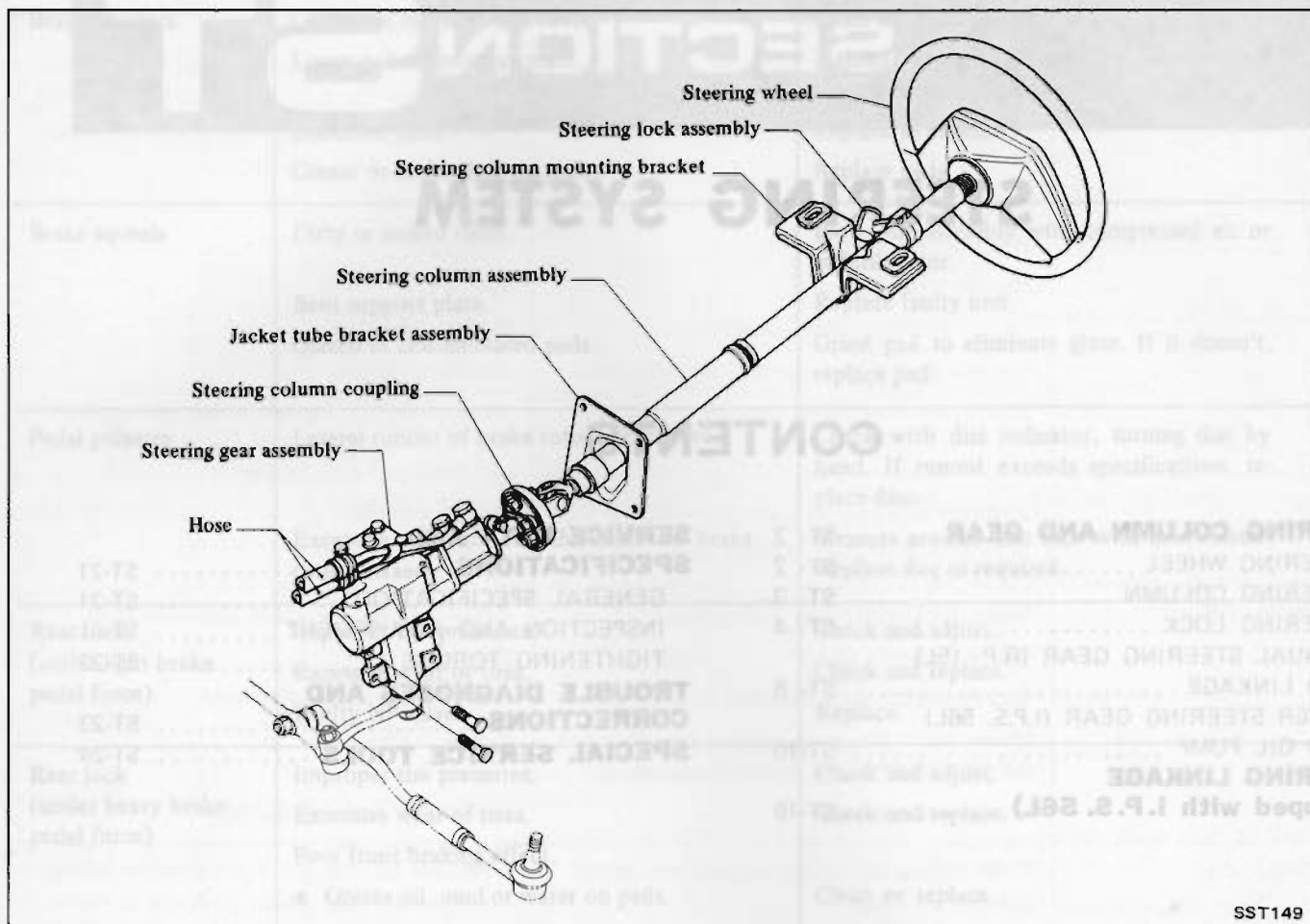

SST149

STEERING WHEEL

REMOVAL

1. Disconnect battery ground cable.
2. Remove horn pad.
3. Remove steering wheel nut.
4. Remove steering wheel using Steering Wheel Puller ST27180001.

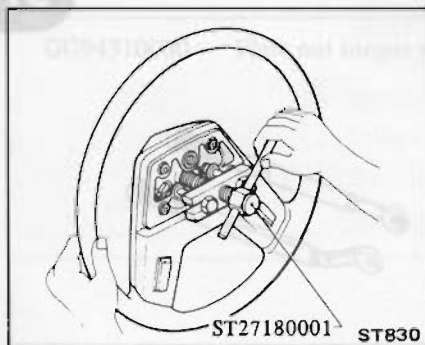

CAUTION:

Do not strike end of steering column shaft with a hammer. Striking shaft will damage bearing or column shaft.

Ⓣ : Steering wheel nut
 39 - 49 N·m
 (4.0 - 5.0 kg·m,
 29 - 36 ft·lb)

After installing steering wheel, turn it clockwise and counterclockwise, checking for catch or drag. Also check horn for operation.

INSTALLATION

Install steering wheel in the reverse order of removal. Observe the following instructions.

1. Apply grease to sliding portions.
2. Install steering wheel on column shaft in a straight ahead position after facing punch mark on the top of upper column shaft in that direction.

STEERING COLUMN

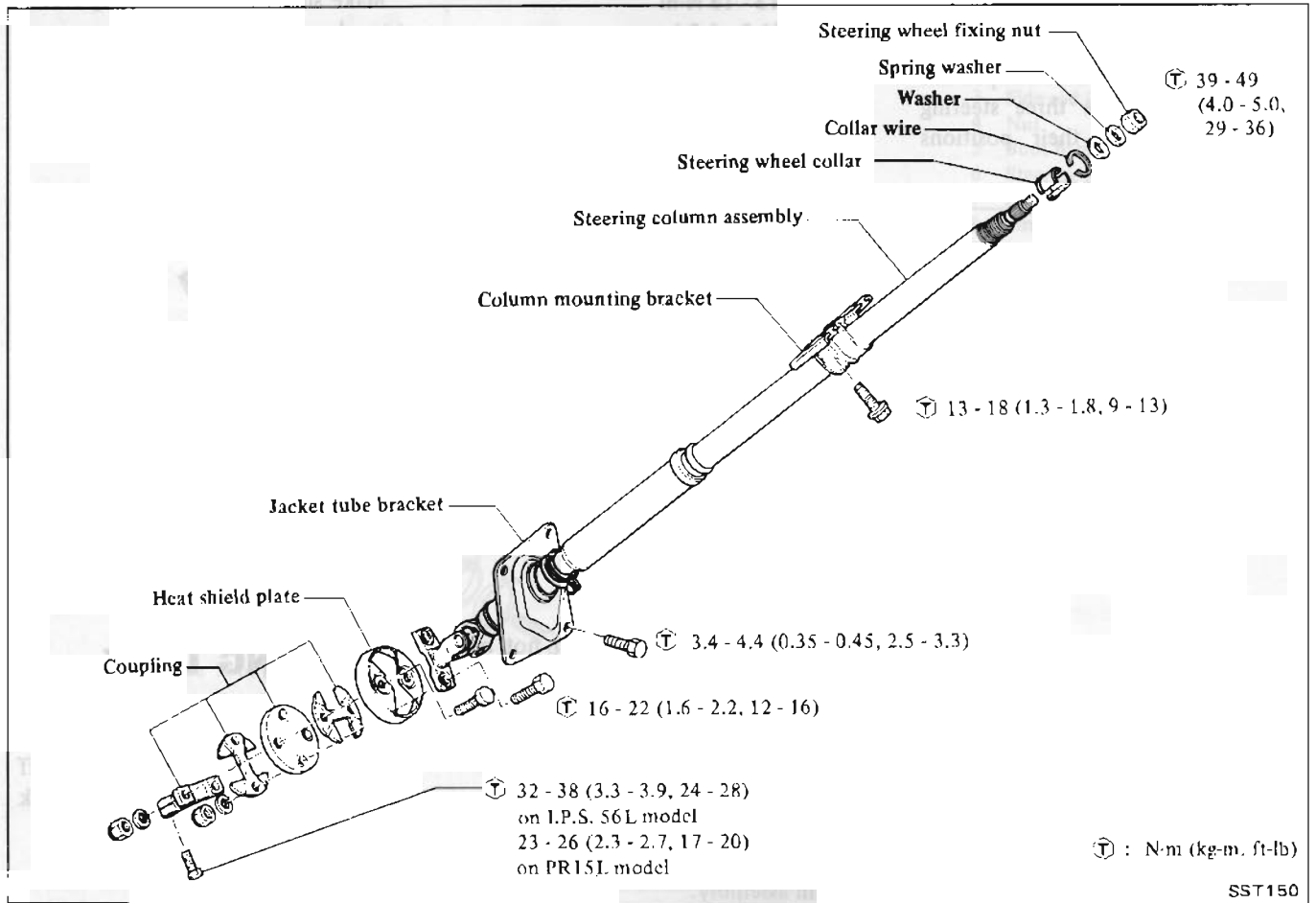

CAUTION:

- a. Never in any case should undue stress be applied to steering column in axial direction.
- b. When installing, do not apply bending force to steering column.

When a head-on collision is encountered, inspect steering system as follows:

The steering system is very important unit for driving. The collapsible type steering column should not be disassembled, and if necessary, replace it as an assembly.

REMOVAL

1. ● I.P.S. model;
 Remove bolt securing stub shaft and rubber coupling.

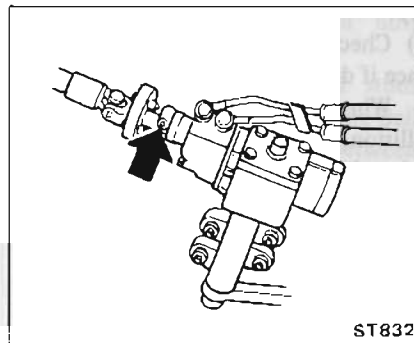

- Manual steering model;
 Remove bolt securing lower joint and rubber coupling.
2. Remove steering wheel. Refer to Steering Wheel.
 3. Remove steering column shell covers.
 4. Remove combination switch assembly.
 5. Remove jacket tube bracket and jacket tube bracket cover from dash panel.

6. Remove column mounting bracket.

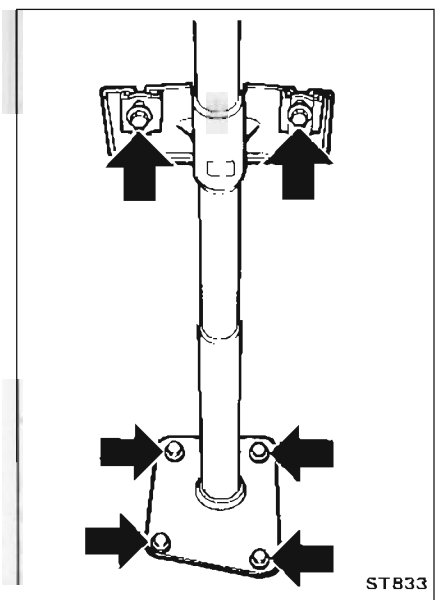

7. Draw out steering column assembly from the room side.

INSTALLATION

Install steering column in reverse order of removal.

1. Remove bands from lower portion of jacket tube. Place three steering column bands into their positions and secure with wires.

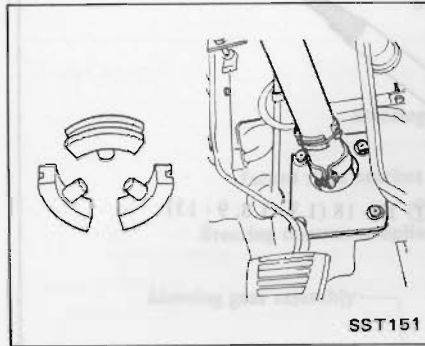

2. Set wheels in a straight ahead position.
3. Fit steering column assembly into stub shaft (or lower joint) serration through dash panel.

Caution: Carefully install so that punch mark at top end of column shaft faces upward.

4. Tighten column mounting bracket temporarily.
5. Tighten stub shaft (or lower joint) securing bolts temporarily to support upper side of steering column assembly.
6. After sliding jacket tube bracket to dash panel, tighten bolts to retain it.

CAUTION:

- a. Make sure that undue stress is not applied to rubber coupling.
- b. To avoid damaging bolt or serrations, align groove in worm shaft with bolt hole in rubber coupling.

- Ⓣ : Jacket tube bracket and cover to dash panel
 - 3.4 - 4.4 N-m
 - (0.35 - 0.45 kg-m,
 - 2.5 - 3.3 ft-lb)

7. Tighten stub (or lower joint) shaft securing bolts and then tighten column mounting bracket securing bolts.

- Ⓣ : Column mounting bracket
 - 13 - 18 N-m
 - (1.3 - 1.8 kg-m,
 - 9 - 13 ft-lb)
- Stub shaft to coupling (I.P.S. model)
 - 32 - 38 N-m
 - (3.3 - 3.9 kg-m,
 - 24 - 28 ft-lb)
- Lower joint to coupling (Manual steering model)
 - 23 - 26 N-m
 - (2.3 - 2.7 kg-m,
 - 17 - 20 ft-lb)

8. Install steering wheel. Refer to Steering Wheel.
9. After installation, make sure that steering wheel turns smoothly.

INSPECTION

1. When steering wheel can not be rotated smoothly, check the steering column for the following matters and replace faulty parts.

(1) Check column bearings for damage or unevenness. If so, lubricate with recommended multi-purpose grease or replace with a new one as steering column assembly.

(2) Check jacket tube for deformation or breakage, and replace if necessary.

(3) Check column spring, and replace if damaged or weakened.

2. When the car comes into light collision, check the following parts and replace if necessary.

(1) Jacket tube

Measure dimension "L".

When jacket tube is crushed, dimension "L" is reduced.

Column length "L":
399.5 - 400.5 mm
(15.73 - 15.77 in)

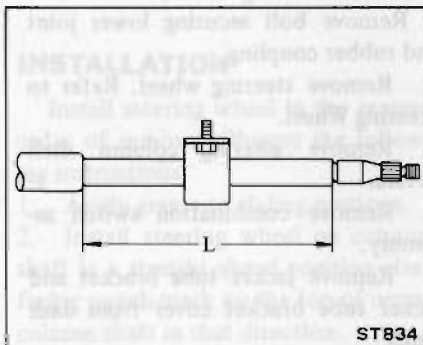

(2) Column mounting bracket

Make sure column mounting bracket touches block.

Measure distance "B". Standard distance "B" is 0 mm (0 in). When jacket tube is crushed, distance "B" becomes larger.

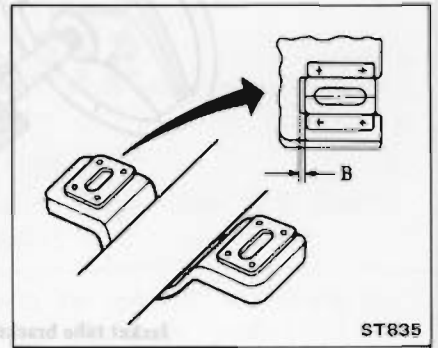

STEERING LOCK

To make steering lock system tamper-proof, self-shear type screws are used; their heads are sheared off upon installation so that steering lock system cannot be easily removed.

REMOVAL

1. Break self-shear type screws with a drill or other appropriate tool.
2. Remove screws and dismount steering lock.

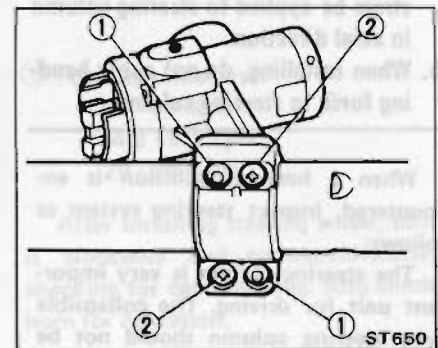

- 1 Self-shear type screw
- 2 Screw

INSTALLATION.

1. Align steering lock hole in jacket tube with mating portion of steering lock.
2. Install self-shear type screws and cut off their heads.

MANUAL STEERING GEAR (R.P. 15L) AND LINKAGE

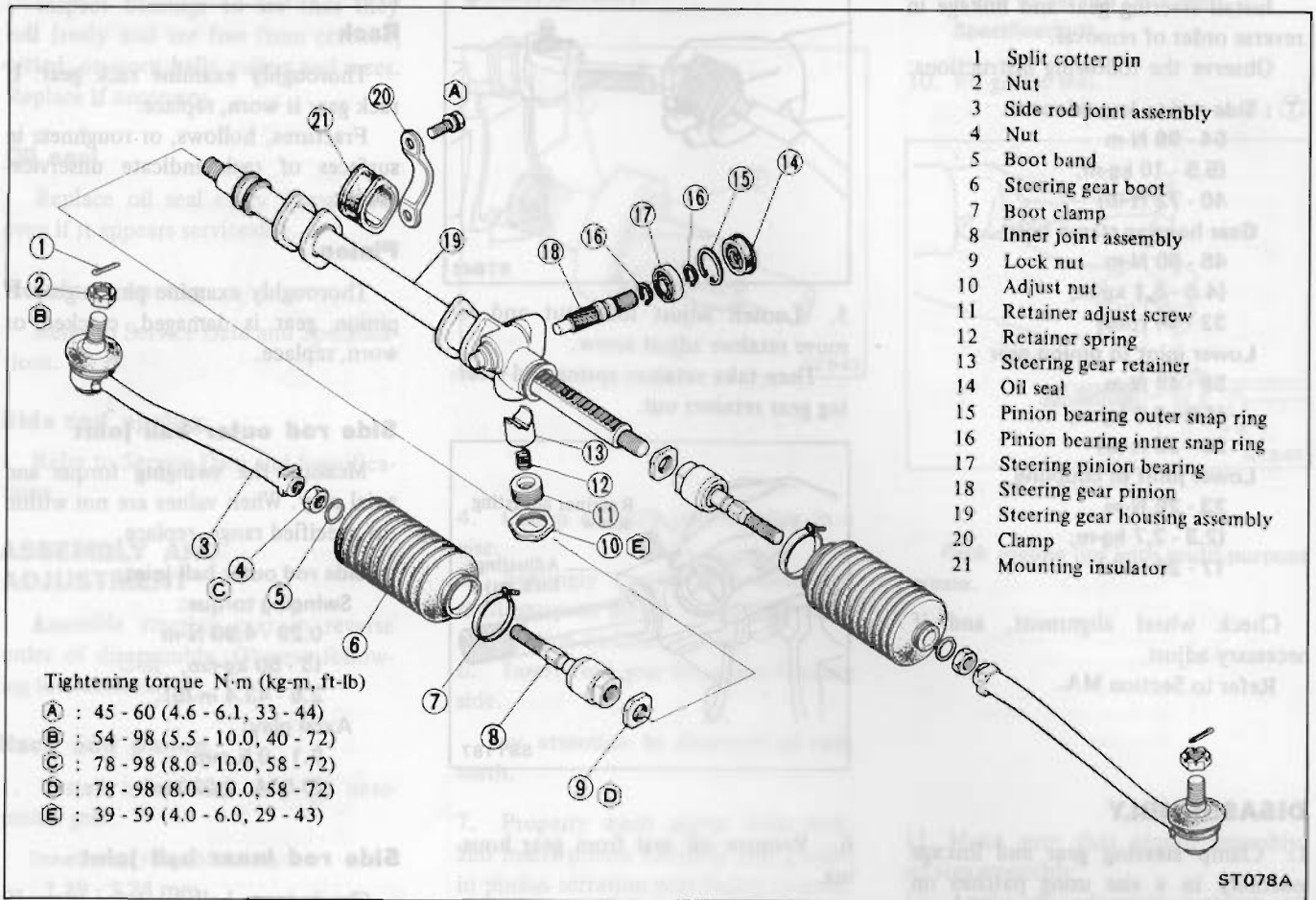

REMOVAL

1. Jack up front of car and support it with safety stand.
2. Loosen bolt securing lower joint shaft to rubber coupling.

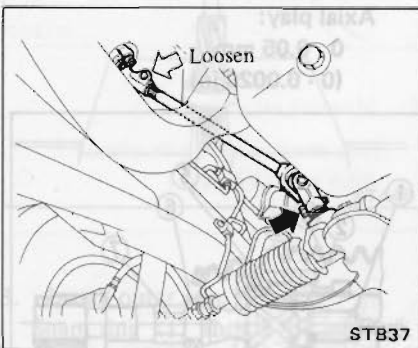

3. Disconnect bolt securing lower joint to steering pinion gear and then draw out lower joint from steering pinion gear.

4. Remove cotter pins and nuts fastening side rod ball studs.
5. To detach side rod ball studs from knuckle arms, insert Steering Ball Joint Remover HT72520000 between them and separate them.

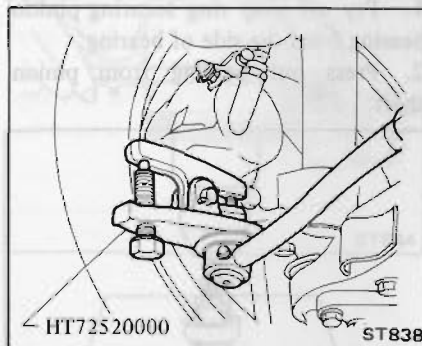

6. Remove bolts securing steering gear housing to suspension cross-member.

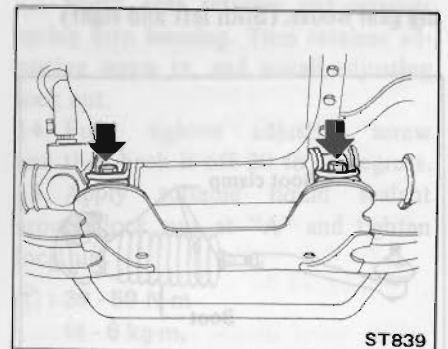

Before removal, loosen nuts mounting front engine mount, place a wooden block under oil pan and jack up so that front engine mount is raised by 10 to 15 mm (0.39 to 0.59 in).

7. Remove steering gear and linkage assembly from car.

INSTALLATION

Install steering gear and linkage in reverse order of removal.

Observe the following instructions:

Ⓣ : Side rod to knuckle arm

54 - 98 N-m
(5.5 - 10 kg-m,
40 - 72 ft-lb)

Gear housing clamp bolt

45 - 60 N-m
(4.6 - 6.1 kg-m,
33 - 44 ft-lb)

Lower joint to pinion gear

39 - 49 N-m
(4.0 - 5.0 kg-m,
29 - 36 ft-lb)

Lower joint to coupling

23 - 26 N-m
(2.3 - 2.7 kg-m,
17 - 20 ft-lb)

Check wheel alignment, and if necessary adjust.

Refer to Section MA.

DISASSEMBLY

1. Clamp steering gear and linkage assembly in a vise using patches on steering gear housing to prevent scarring.

2. Remove boot clamps from steering gear boots. (Both left and right)

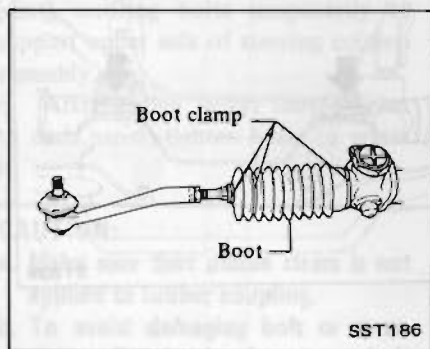

3. Loosen inner joint lock nut.
4. Remove side rod assembly from rack.

CAUTION:

Do not disassemble inner joint assembly and side rod socket assembly.

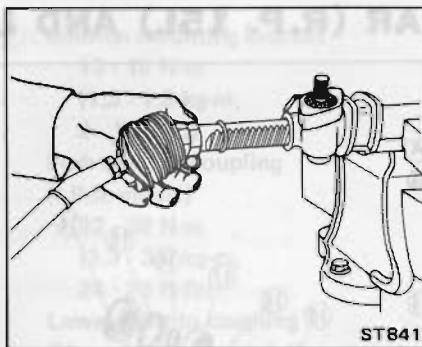

5. Loosen adjust lock nut and remove retainer adjust screw.

Then take retainer spring and steering gear retainer out.

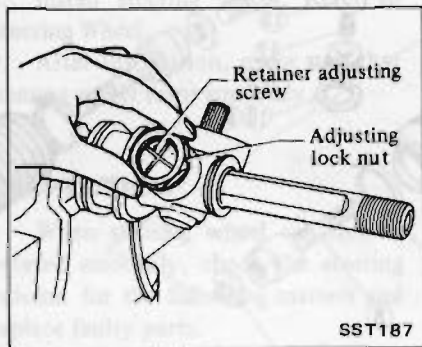

6. Remove oil seal from gear housing.

Oil seal must not be reused.

7. Pry off snap ring from gear housing.

8. Draw steering pinion assembly out.

9. Draw rack out from gear housing.

Pinion gear

1. Pry off snap ring securing pinion bearing from the side of bearing.

2. Press out bearing from pinion shaft.

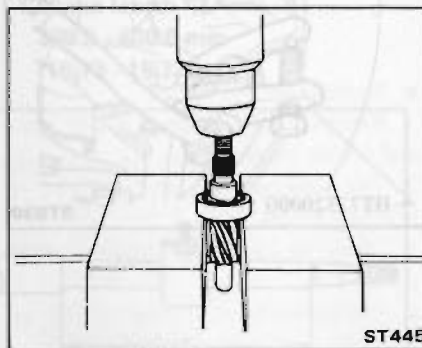

INSPECTION

Thoroughly clean all parts in clean-

ing solvent, and blow dry with compressed air, if available.

Rack

Thoroughly examine rack gear. If rack gear is worn, replace.

Fractures, hollows, or roughness in surfaces of rack indicate unserviceability.

Pinion

Thoroughly examine pinion gear. If pinion gear is damaged, cracked or worn, replace.

Side rod outer ball joint

Measure the swinging torque and axial play. When values are not within the specified range, replace.

Side rod outer ball joint:

Swinging torque:

0.29 - 4.90 N-m
(3 - 50 kg-cm,
2.6 - 43.4 in-lb)

Axial play:

0.1 - 0.5 mm
(0.004 - 0.020 in)

Side rod inner ball joint

Check inner ball joint for play. If ball stud is worn and play in axial direction is excessive or joint is hard to swing, replace as a complete unit.

Side rod inner ball joint:

Swinging torque:

0 - 4.9 N-m
(0 - 50 kg-cm,
0 - 43 in-lb)

Axial play:

0 - 0.05 mm
(0 - 0.0020 in)

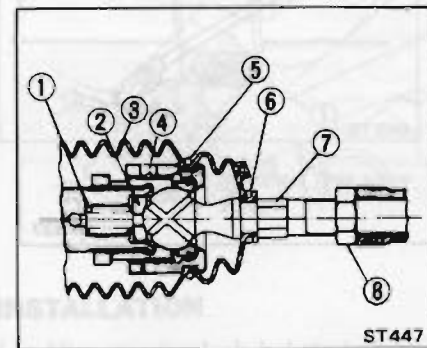

- 1 Side rod spring
- 2 Spring seat
- 3 Boot
- 4 Welded
- 5 Dust cover clamp
- 6 Boot clamp
- 7 Side rod ball
- 8 Stopper nut

Pinion bearing

Inspect bearings to see that they roll freely and are free from cracked, pitted, or worn balls, rollers and races. Replace if necessary.

Oil seal

Replace oil seal every disassembly even if it appears serviceable.

Retainer spring

Refer to Service Data and Specifications.

Side rod spring

Refer to Service Data and Specifications.

ASSEMBLY AND ADJUSTMENT

Assemble steering gear in reverse order of disassembly. Observe following instructions.

Rack and pinion

1. Install inner snap ring ② onto pinion gear.

Inner snap ring thickness:
1.19 - 1.24 mm
(0.0469 - 0.0488 in)

2. Press bearing onto pinion gear.

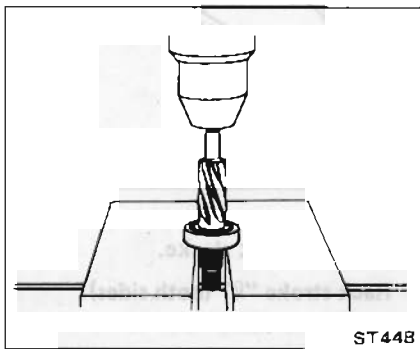

3. Install outer snap ring ①.

Snap ring ① should be of such thickness that axial play is less than 0.1 mm (0.004 in).

To ensure proper axial play, select snap ring of proper thickness.

Pinion bearing inner snap ring:
Refer to Service Data and Specifications.

Snap rings should be fitted to grooves correctly.

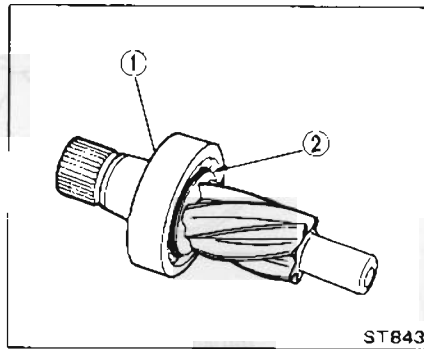

4. Clamp steering gear housing in a vise.

5. Sparingly apply recommended multi-purpose grease to toothed faces and friction surfaces of rack.

6. Insert rack gear from gear housing side.

Pay attention to direction of rack teeth.

7. Properly mesh pinion with rack, and insert pinion assembly into groove in pinion serration part facing upward.

8. Make sure that rack protrudes by the same amount from both ends of housing.

Standard length "L" (both sides)
L: 89.4 mm (3.520 in)

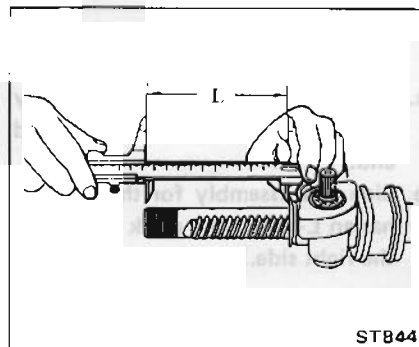

9. Secure pinion bearing to gear housing with snap ring.

Snap ring should be of such thickness that axial play is less than 0.1 mm (0.004 in).

Pinion bearing outer snap ring:
Refer to Service Data and Specifications.

10. Fit grease seal.

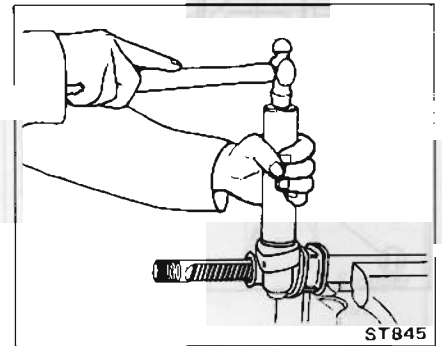

Pack sealing lips with multi-purpose grease.

11. Make sure that pinion assembly rotates smoothly.

12. Apply an adequate amount of recommended multi-purpose grease to steering gear retainer.

13. Insert gear retainer and retainer spring into housing. Turn retainer adjusting screw in, and install adjusting lock nut.

14. Fully tighten adjusting screw and then back it off 20 to 25 degrees.

15. Apply suitable liquid sealant around lock nut at "A" and tighten lock nut.

⊕ : 39 - 59 N·m
(4 - 6 kg·m,
29 - 43 ft·lb)

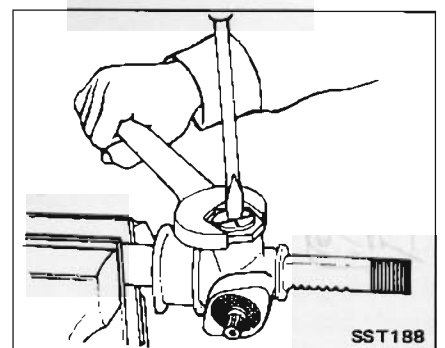

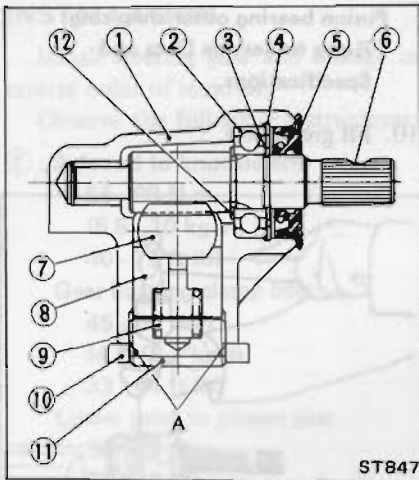

- 1 Steering gear housing
- 2 Steering pinion bearing
- 3 Snap ring
- 4 Pinion bearing outer snap ring
- 5 Oil seal
- 6 Steering gear pinion
- 7 Steering rack gear
- 8 Steering gear retainer
- 9 Retainer spring
- 10 Lock nut
- 11 Retainer adjust screw
- 12 Snapring

16. Upon completion of gear assembly measure the torque required to keep pinion and rack in motion. Re-adjust retainer adjusting screw as necessary to obtain proper torque.

Pinion (turning torque):

Less than 2.0 N·m
(20 kg·cm, 17 in·lb)

Rack (force to pull at neutral position):

Less than 98 N
(10 kg, 22 lb)

Both parts should move smoothly over their entire travel.

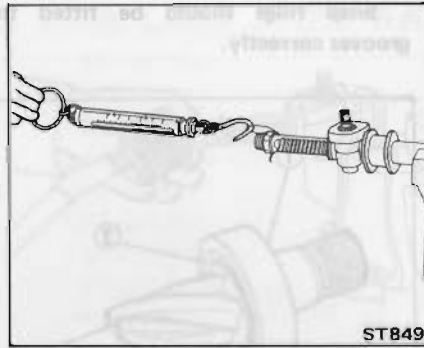
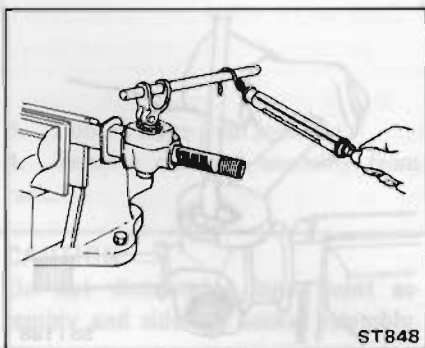

Side rod and gear boot

1. Fit boot and small clamp on side rod assembly.
2. Thread lock nut and lock nut over the threaded portion of rack.
3. Apply an adequate amount of recommended multi-purpose grease to the sliding surfaces of side rod inner joint and spring seat.
4. Fit side rod assembly to rack end together with inner spring and spring seat.

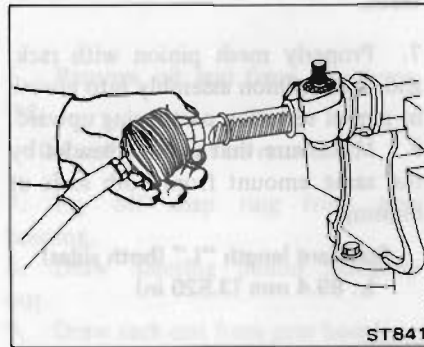

- a. Make sure that boot is carefully positioned toward the ball stud end.
- b. Side rod assembly for the left side has an L-mark. (No mark is used for the right side.)

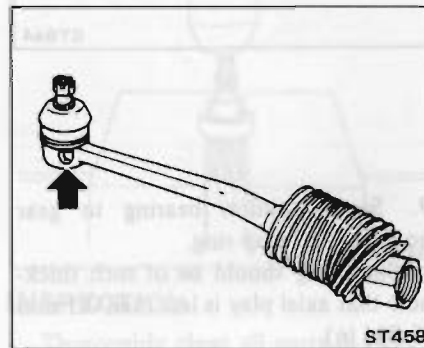

5. Screw inner socket portion until ball seat reaches the rack end, and then tighten lock nut securely.

T : 78 - 98 N·m
(8 - 10 kg·m,
58 - 72 ft·lb)

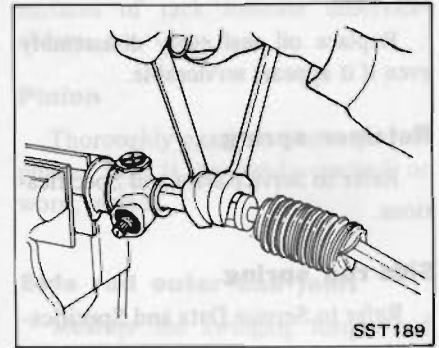

6. Upon completion of side rod assembly, measure swinging torque and axial play of inner ball joint.

Swinging torque:

0 - 4.9 N·m
(0 - 50 kg·cm,
0 - 43 in·lb)

Axial play:

0 - 0.05 mm
(0 - 0.0020 in)

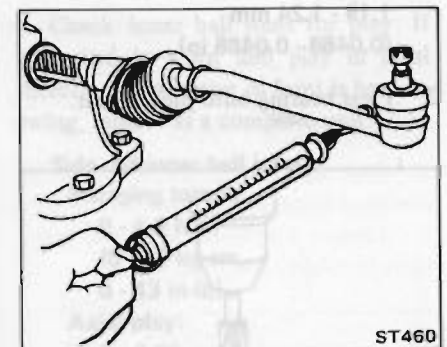

7. Measure rack stroke.

Rack stroke "ℓ" (both sides):
66.4 mm (2.614 in)

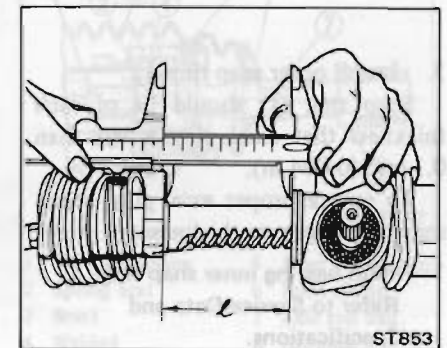

8. Fit large boot clamp at inner socket, install a grease nipple at both ends of rack, and apply recommended multi-purpose grease to each joint.

Lubrication of the rack ends is made so that a small quantity of new grease appears at the boot grease outlet hole.

Do not apply an excessive amount of grease.

9. Install boot to gear housing, then tighten inside boot clamp securely.

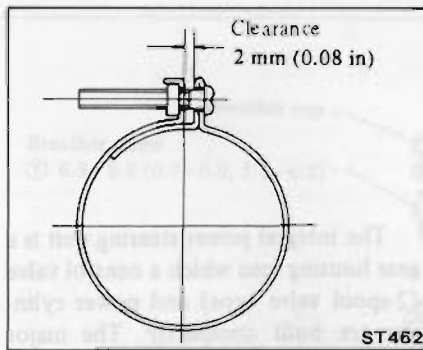

ST462

Boot should be neither too inflated nor too elongated.

10. Adjust the side rod length both left and right, and tighten steering stopper nuts.

Ⓣ : 78 - 98 N-m
(8 - 10 kg-m,
58 - 72 ft-lb)
Side rod length "L"
29.5 mm (1.161 in)

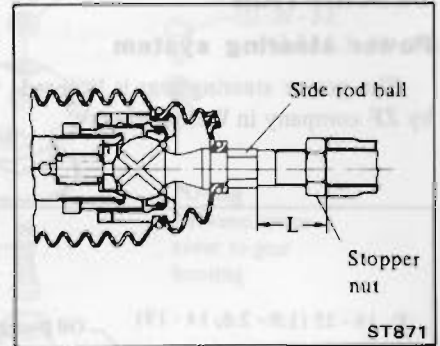

ST871



POWER STEERING GEAR (I.P.S. 56L) AND OIL PUMP

DESCRIPTION

Power steering system

The power steering gear is licensed by ZF company in West Germany.

The integral power steering unit is a gear housing into which a control valve (2-spool valve type) and power cylinder are built compactly. The major

components are as follows:

- Oil pump
- Power steering gear
- Oil piping

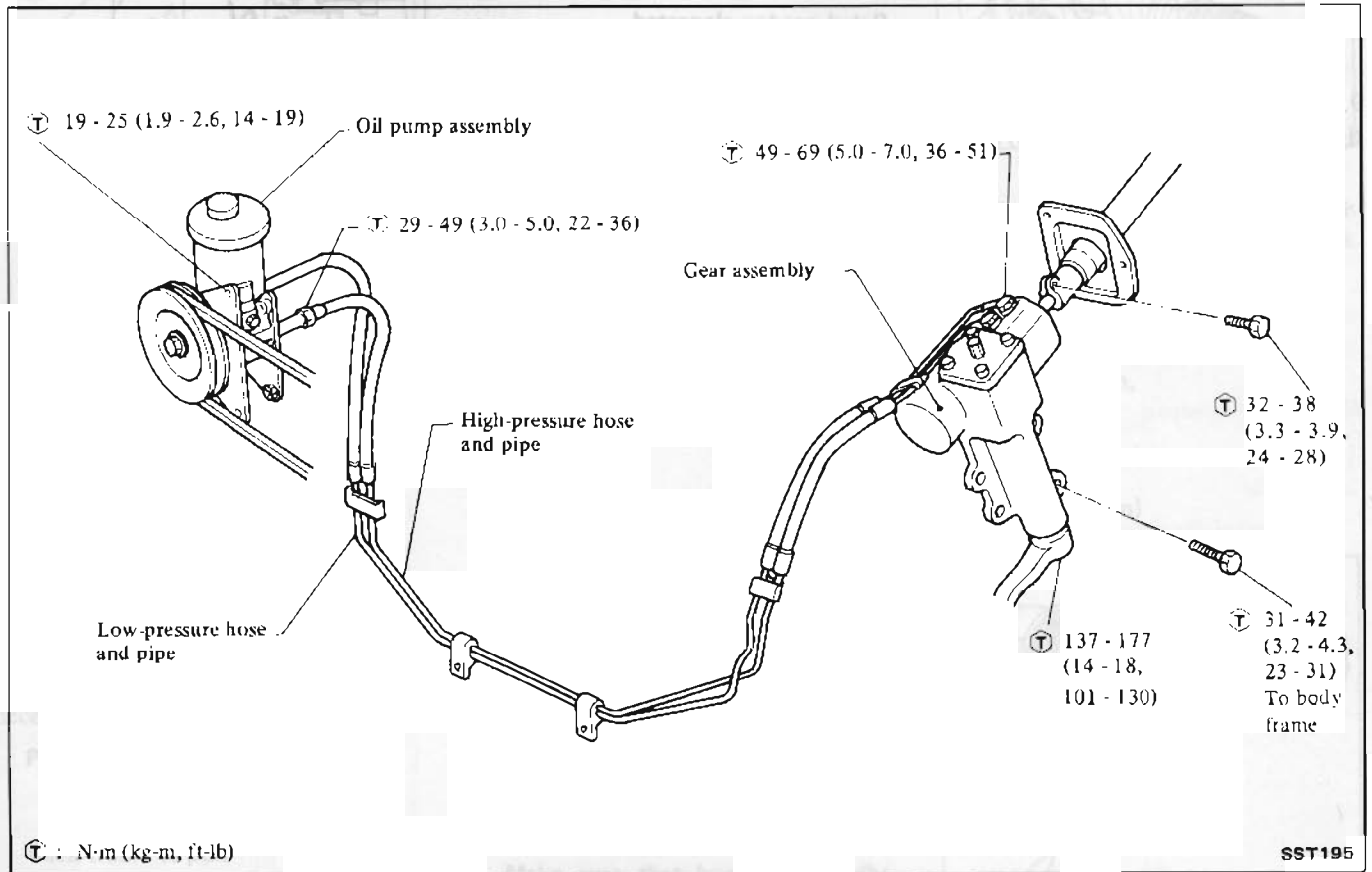

Power steering gear

The integral power steering gear is an accurate oil pressure mechanism. In disassembling it, be careful to keep dust, iron powder and other foreign particles out of the gear housing.

Only the sealing parts of the gear assembly can be replaced. The remaining parts must be replaced as an gear assembly.

CAUTION:

- a. The parts which can be disassembled are strongly restricted, and never disassemble other parts than the specified ones. If parts not indicated in the manual are also disassembled, replace the assembly instead of reassembling those parts.
- b. Disassembly of integral power steering gear should be performed in a place as clean as possible, although a dust preventing device is not required.

- c. Should disassembly of integral power steering gear remain unfinished for any reason, indicate it as "Half Disassembled" and cover parts with a clean cover.
- d. Hands should be cleaned immediately before disassembly.
- e. Do not use a rag. Be sure to use nylon or paper cloth.
- f. Be sure to follow procedures and cautions indicated in the Service Manual.

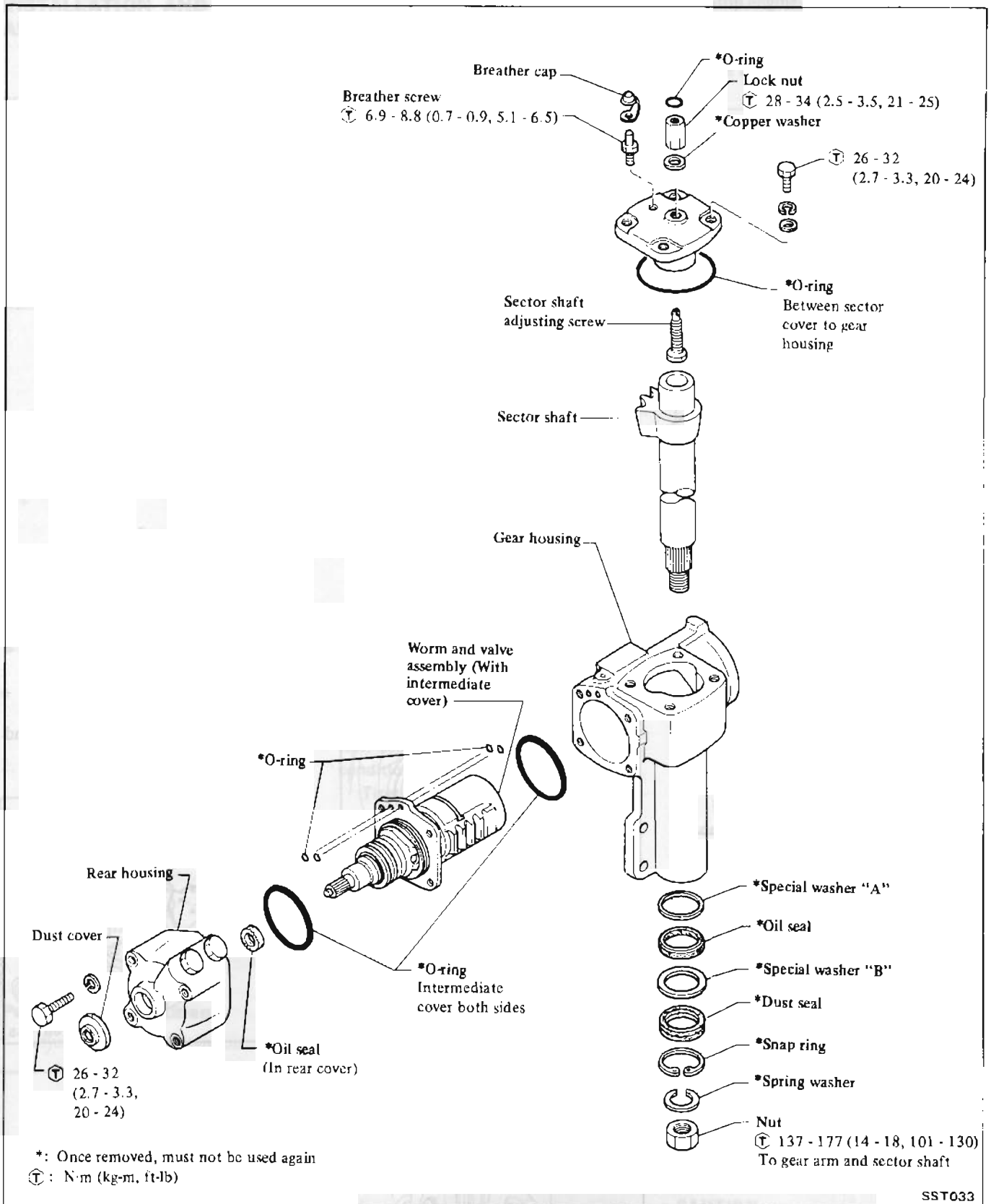

SST033

Oil pump

Malfunctioning (Replace as an oil pump assembly).

REMOVAL

Before removing, clean exteriors of gear housing and oil pump with steam and dry with compressed air.

Steering gear

Pot coupling to stub shaft
Ⓣ 32 - 38 (3.3 - 3.9, 24 - 28)

Hose to gear housing
Ⓣ 49 - 69 (5.0 - 7.0, 36 - 51)

Gear housing to body
Ⓣ 31 - 41 (3.2 - 4.2, 23 - 30)

Sector shaft to gear arm
Ⓣ 137 - 177 (14 - 18, 101 - 130)

- Remove gear arm

ST29020001

- Install gear arm
Align four grooves of gear arm serrations with four projections of sector shaft serrations, and install and tighten lock washer and nut.

- Plug openings of gear housing, and securely locate hose connectors at a position higher than oil pump and cover with rag.
- Be extremely careful to prevent entry of foreign matter into hoses through connectors.

Ⓣ : N·m (kg·m, ft·lb)
▲ : Removing points

SST034

Oil pump

- Loosen oil pump pulley lock nut. Turn belt adjusting bolt counter-clockwise.

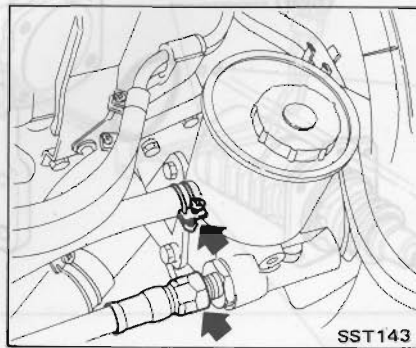
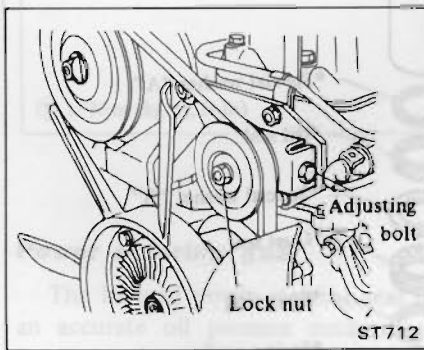

- Remove oil pump.

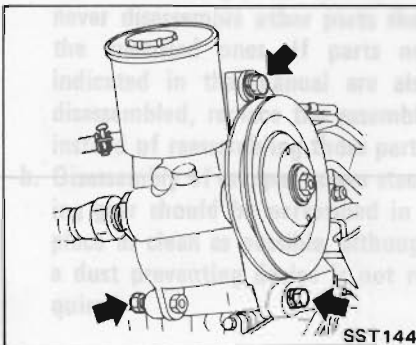

- Disconnect hoses from pump.
- Remove oil pump brackets and other brackets from engine.

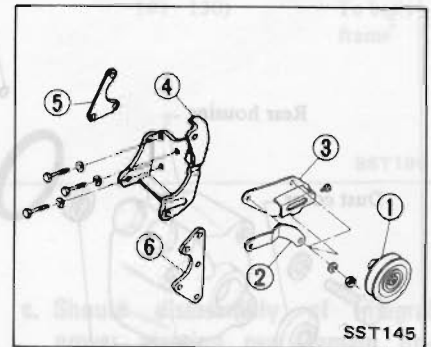

- Compressor idler pulley
- Oil pump support
- Idler pulley bracket
- Fuel pump gasket
- Fuel pump cover
- Oil pump bracket

- Unfasten hose clamps, and remove hoses from engine compartment.

INSTALLATION AND ADJUSTMENT

Install steering gear in the reverse order of removal.

Fluid level

1. Check fluid level in oil pump assembly with dipstick whether fluid level is on HOT side at normal operating temperature or on "COLD" side when oil is cold.

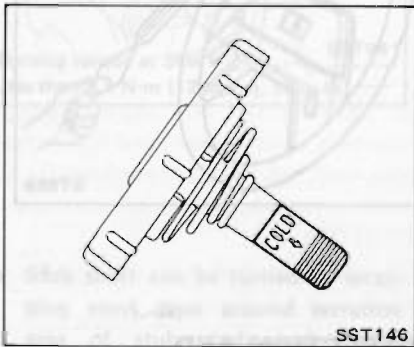

- Do not overfill with fluid.
 - Normal operating temperature is 60 to 80°C (140 to 176°F).
 - When running engine, make sure fluid level variations in opening oil pump are less than 2 mm (0.08 in).
2. Check fluid level and leakage.

Recommended fluid is Automatic Transmission Fluid "Dexron Type". Refer to Section MA for "Recommended Lubricant".

Fluid capacity:

Approximately
500 - 600 ml
(16.9 - 20.3 US fl oz,
17.6 - 21.1 Imp fl oz)

Pump belt adjustment

Adjust oil pump belt tension.

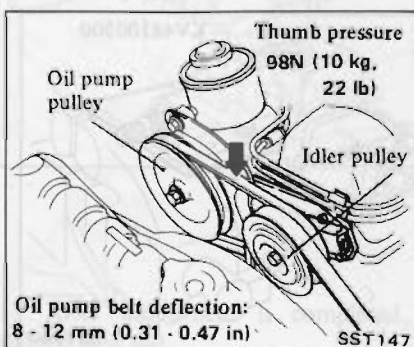

Check fluid leakage

1. Run engine at idle speed or 1,000 rpm.

Make sure temperature of fluid in pump rises to 40 to 60°C (104 to 140°F) with a temperature indicator.

2. Turn steering wheel to right-to-left several times.

3. Hold steering wheel at each "lock" position for five seconds and carefully check the following points for fluid leakage.

- Oil seal at rear cover
- Intermediate cover
- Adjusting screw lock nut
- Sector shaft oil seal
- Sector cover O-ring
- Oil pressure line connectors

CAUTION:

Do not hold steering wheel at lock position for more than fifteen seconds at a time.

Hydraulic system check

To determine whether problem is in steering gear or oil pump, measure operating pressure.

Before conducting hydraulic system test, carefully check belt tension and condition of driving pulley.

Tires must be inflated to normal pressure.

1. Check fluid level and fluid leakage, adding oil if necessary.

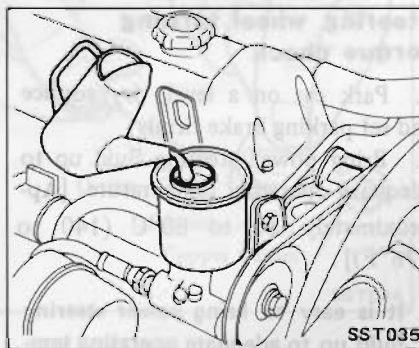

2. Run engine.

Make sure temperature of fluid in pump rises to 40 to 60°C (104 to 140°F) with a temperature indicator.

3. Stop engine.

4. Set Tool.

- Gauge must be between shut-off valve and oil pump.

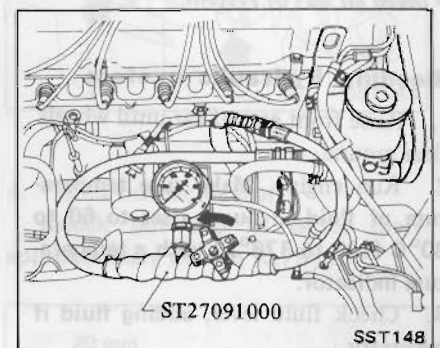
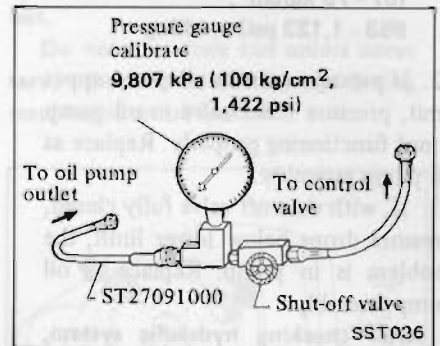

5. Open shut-off valve at Tool.
6. Check fluid level, adding fluid if necessary.
7. Run engine at idle for 3 to 5 seconds.
8. Stop engine and check fluid level, adding fluid if necessary.
9. Run engine and check fluid level again, adding oil if necessary.
10. Turn steering wheel fully in left or right until fluid reaches operating temperature.

- Be sure that all connections are tight.
 - Expel any air from system.
11. Slowly close shut-off valve with steering wheel fully turned in left or right and lightly touch wheel stopper.

CAUTION:

Do not close shut-off valve for more than fifteen seconds, as this would abnormally increase lubricant temperature and cause undue pump wear.

With valve fully closed, pump pressure should be at maximum.

Normal pressure:

6,571 - 7,748 kPa
(67 - 79 kg/cm²,
953 - 1,123 psi) at idling

12. If pressure increases beyond upper limit, pressure relief valve in oil pump is not functioning properly. Replace as oil pump assembly.

13. If, with shut-off valve fully closed, pressure drops below lower limit, the problem is in pump. Replace as oil pump assembly.

After checking hydraulic system, add fluid as necessary, then completely bleed air out of system.

Bleeding hydraulic system

1. Raise front end of car until wheels clear ground.
2. Run engine. Make sure temperature of fluid in pump rises to 60 to 80°C (140 to 176°F) with a temperature indicator.
3. Check fluid level, adding fluid if necessary.

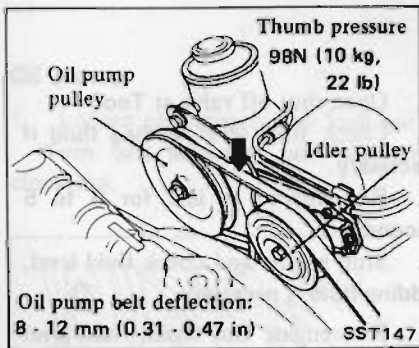

4. Run engine for 3 to 5 seconds.
5. Stop engine, adding fluid if necessary.
6. Quickly turn steering wheel all the way to right and left ten times and lightly touch wheel stoppers.
7. Check fluid level, adding fluid if necessary.
8. Start engine at idle.

Repeat steps 4 through 8 until air will be bled from pump.

9. With steering wheel fully turned to left, open bleeder screw to expel air, and then tighten bleeder screw.

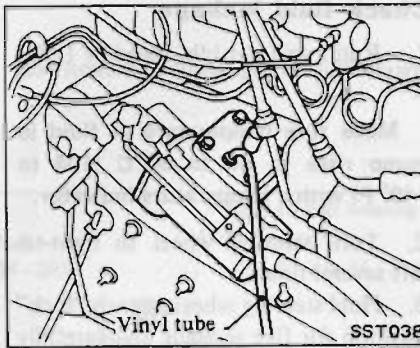

- Operation should be performed, making sure that fluid level is kept within specified limit.
- Repeat this operation until air bleeding is completed.

10. If air cannot be bled completely in steps 1 through 9, proceed as follows:

- (1) With engine running at 1,000 to 1,500 rpm, repeat step 9.
- (2) Turn steering wheel to right and left from lock to lock five to ten times. Carefully check fluid leakage with steering wheel held at each lock position for five seconds.

CAUTION:

Do not hold steering wheel at lock position for more than fifteen seconds at a time.

Steering wheel turning torque check

1. Park car on a level, dry surface and set parking brake firmly.
2. Bring power steering fluid up to adequate operating temperature. [Approximately 60 to 80°C (140 to 176°F)].

- It is easy to bring power steering fluid up to adequate operating temperature by idling engine and at the same time turning steering wheel from left to right for about two minutes. Alternatively, drive car several miles.
- Tires must be inflated to normal pressure.

3. Check steering wheel turning torque when steering wheel has been turned 360° from straight-ahead position.

Steering wheel turning force:

24.5 - 29.4 N
(2.5 - 3.0 kg, 5.5 - 6.6 lb)
at circumference of steering wheel

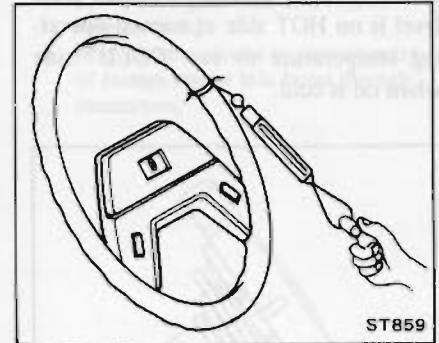

INSPECTION AND ADJUSTMENT

Wash clean all disassembled parts in suitable cleaning solvent and check their condition.

Check sealing portion.

- Adjusting screw nut O-ring.
 - Sector shaft cover O-ring
 - Sector shaft oil seal
 - Rear housing oil seal
 - Intermediate cover O-ring
- Discard any oil seal and O-ring which have once been removed.
- Replace oil seal and O-ring if sealing surface is deformed or cracked.

Turning torque measurement

1. Measure turning torque at 360° position.

- (1) Install steering gear on Tool.

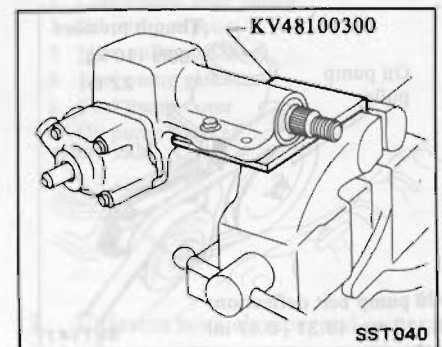

- (2) Turn stub shaft all the way to right and left several times.
- (3) Measure turning torque at 360° position from straight-ahead position using Tool.

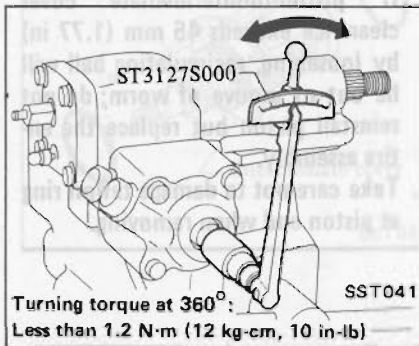

- Stub shaft can be turned by wrapping vinyl tape around serration area of stub shaft and fitting wrench socket.
- If it is beyond specification, gear must be replaced as an assembly.

2. Measure turning torque at straight-ahead position.

- (1) Set worm gear in a straight-ahead position.

Straight-ahead position is a position where stub shaft is turned two turns by 45° from lock position.

- (2) Measure turning torque using Tool.

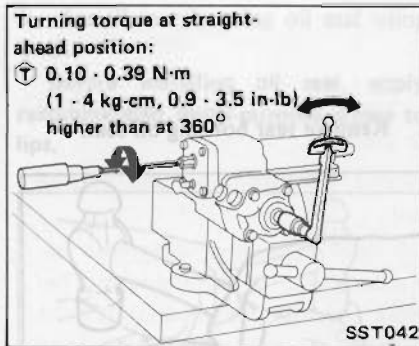

5. After adjustment is completed, tighten lock nut.

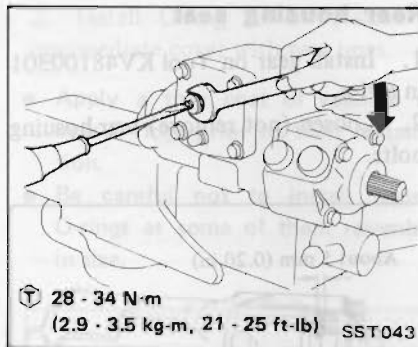

Measure turning torque. If they are not within specifications, replace gear assembly.

DISASSEMBLY

Before disassembly, measure turning torque.

If they are not within specifications, replace steering gear assembly.

CAUTION:

Each oil sealing parts, dust cover, special washer and snap ring once removed must not be used again.

Adjusting screw lock nut seal

Remove adjusting screw lock nut, and replace O-ring.

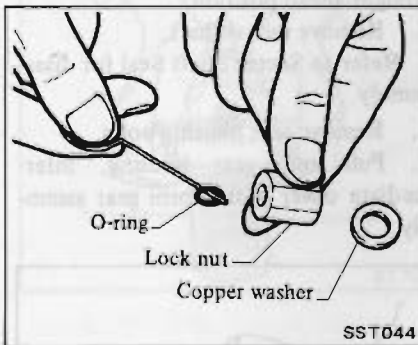

Sector shaft oil seal

1. Install steering gear on Tool KV48100300.
2. Set stub shaft in a straight-ahead position.

Straight-ahead position is a position where stub shaft is turned two turns by 45° from lock position.

3. Disconnect sector shaft cover bolt.
- Do not loosen adjusting screw lock nut.

Do not turn lock nut unless necessary; otherwise it will damage O-ring, resulting in an oil leak.

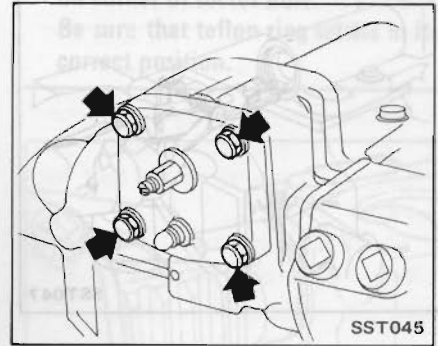

4. Draw out sector shaft.

Knock out end of sector shaft approximately 20 mm (0.79 in).

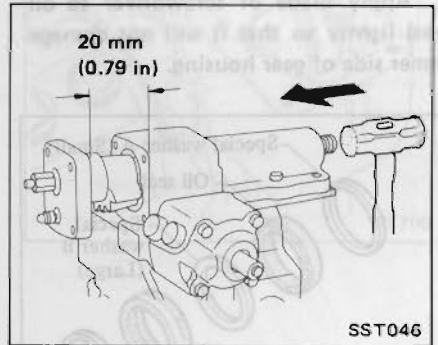

5. Connect a roll of plastic film to sector shaft.

Plastic film:

Thickness 0.1 mm (0.004 in)
Length x width
200 x 200 mm (7.87 x 7.87 in)

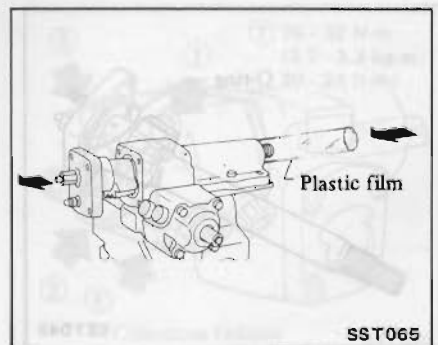

6. Pull out sector shaft by hand.

Attach plastic film to two bearings located inside gear housing while simultaneously pulling out sector shaft so that bearings will not drop into housing.

7. Remove snap ring.

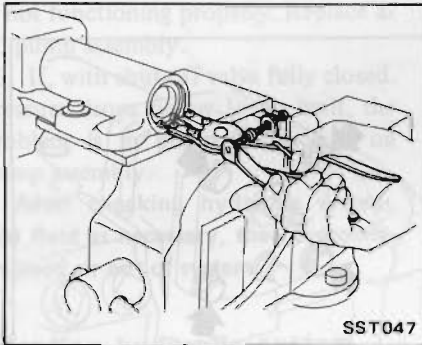

8. Remove dust cover, special washers and oil seal.

Apply blade of screwdriver to oil seal lightly so that it will not damage inner side of gear housing.

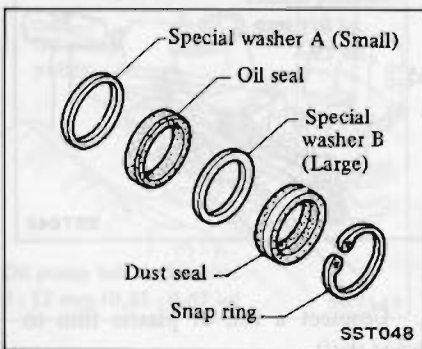

9. Remove O-ring.

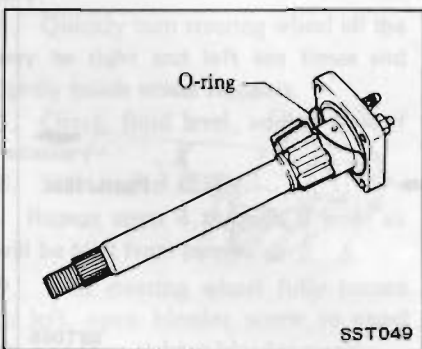

Rear housing seal

1. Install gear on Tool KV48100301 in a vise.
2. Loosen (not remove) rear housing bolts.

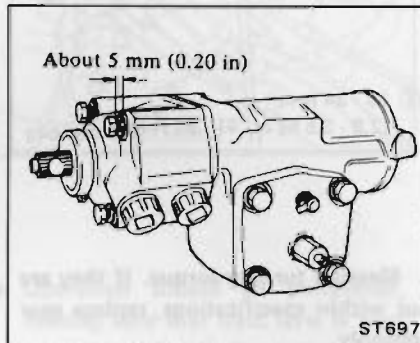

3. Turn sector shaft clockwise slightly to raise intermediate cover through piston.

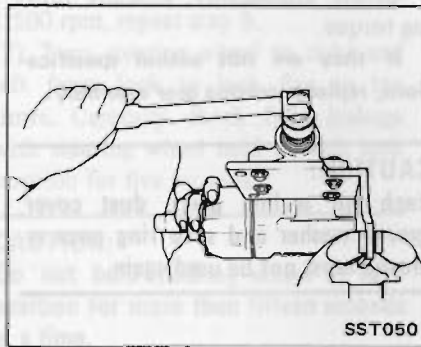

4. Turn stub shaft counterclockwise and place piston (worm gear) in its straight-ahead position.

5. Remove sector shaft.

Refer to Sector Shaft Seal for disassembly.

6. Remove rear housing bolts.

7. Pull out rear housing, intermediate cover with worm gear assembly.

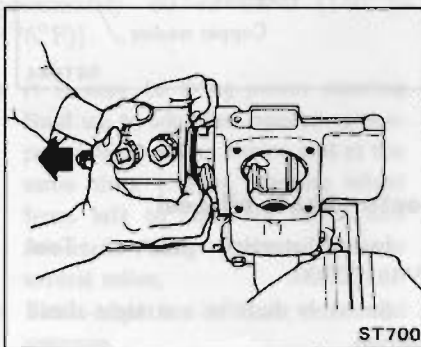

CAUTION:

- a. When worm assembly is removed, piston may turn and come off under its own weight. Hold piston to prevent it from turning. If piston-to-intermediate cover clearance exceeds 45 mm (1.77 in) by loosening, recirculating ball will be out of groove of worm; do not reinstall piston but replace the entire assembly.
- b. Take care not to damage teflon ring at piston end when removing.

8. Remove rear housing, turn worm assembly upside down, and lightly tap stab shaft end on top of workbench.

CAUTION:

Do not strike shaft with a hammer or pry it with a screwdriver.

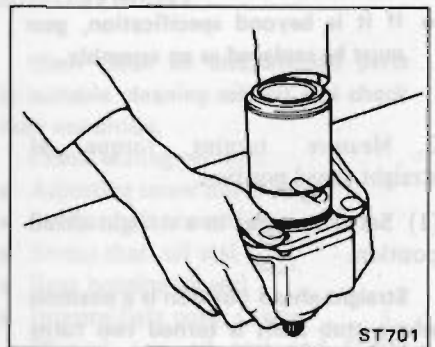

9. Remove rear housing oil seal.

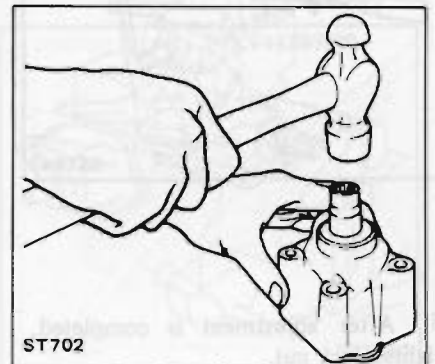

10. Remove O-ring on both sides of intermediate cover.

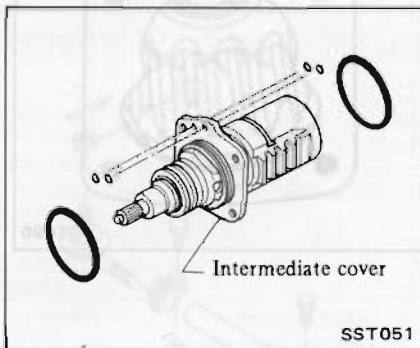

2. Install O-ring on both sides of intermediate cover with new ones.

- Apply a thin coat of vaseline to new O-rings prior to their installation.
- Be careful not to install wrong O-rings as some of them resemble in size.

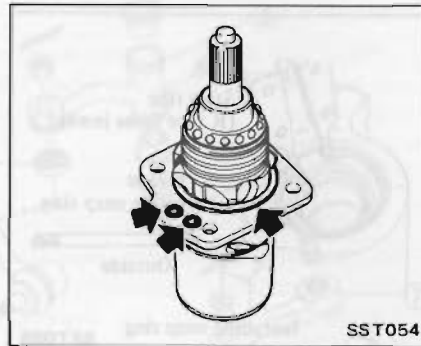

CAUTION:

- Be careful that teflon ring at piston end is not damaged during insertion of gear housing.
- When worm assembly is halfway inserted, teflon ring is deflected. Insert remaining part of worm assembly paying particular attention. Take care not to damage teflon ring on corner of sector hole. Be sure that teflon ring settles in its correct position.

ASSEMBLY

Adjusting screw lock nut seal

Insert new O-ring into adjusting screw lock nut.

- Before inserting, apply a thin coat of vaseline to O-ring.
- Insert O-ring to make sure it fits into groove.

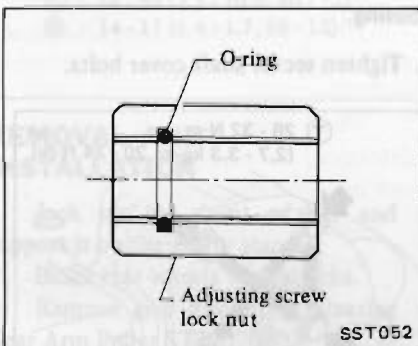

3. Fit rear housing onto intermediate cover with worm gear assembly.

CAUTION:

- Do not tilt ball bearing.
- Make sure that O-rings are not protruding or extruding.

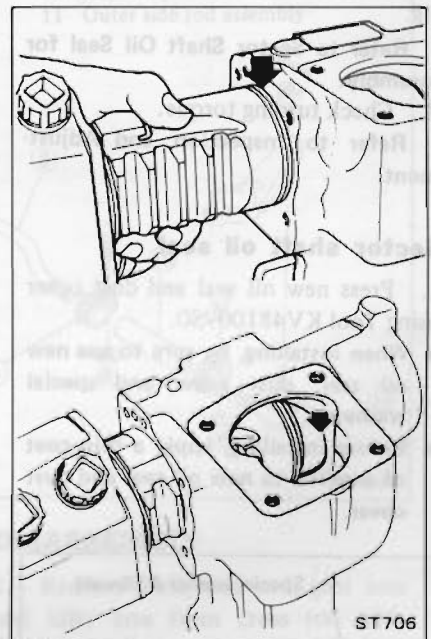
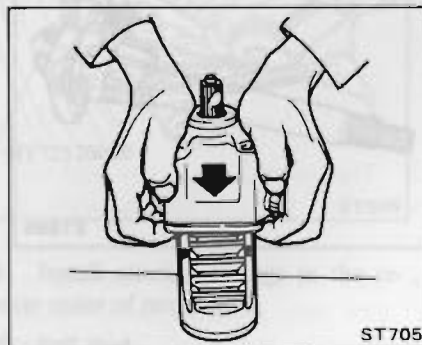

Rear housing seal

1. Install rear housing oil seal using Tool.

Before installing oil seal, apply recommended multi-purpose grease to lips.

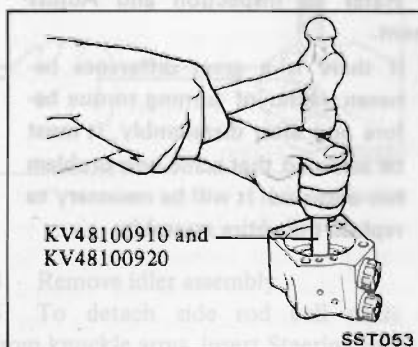

5. Gradually tighten rear housing bolts in a criss-cross fashion.

4. Insert worm gear assembly with rear housing and intermediate cover into gear housing.

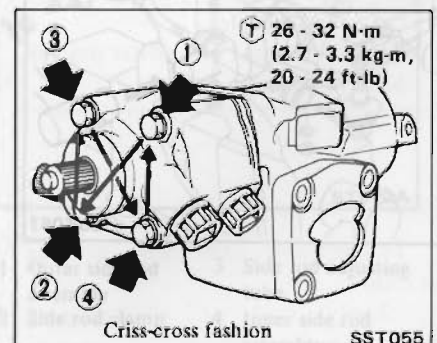

CAUTION:

- a. If bolts are tightened while worm assembly is tilted, inner seals will be damaged. Tighten bolts while assembly is level.
If worm assembly is tilted, stub shaft's turning torque will be increased.
- b. Check O-rings to ensure that they do not protrude or extrude.

6. Install sector shaft into gear housing.

Refer to Sector Shaft Oil Seal for assembly.

7. Check turning torque.

Refer to Inspection and Adjustment.

Sector shaft oil seal

1. Press new oil seal and dust cover using Tool KV481009S0.

- When installing, be sure to use new oil seal, dust cover and special washers.
- Before installing, apply a thin coat of vaseline to new oil seal and dust cover.

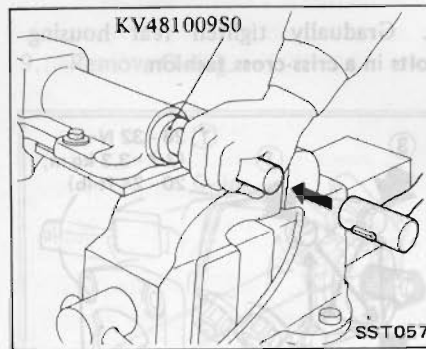

2. Install a new snap ring into gear housing.

CAUTION:

- a. Turn snap ring to make sure it fits into groove.
- b. Always install snap ring with its rounded edges facing oil seal.

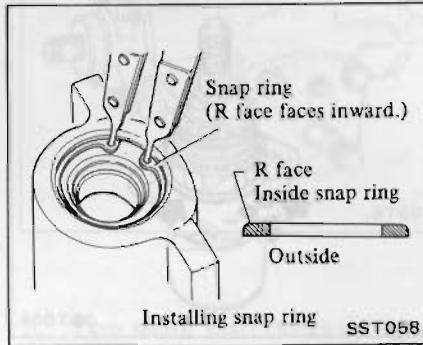

3. Fit new O-ring into sector shaft cover.

- Before installing, apply a thin coat of vaseline to O-ring.
- Make certain that O-ring is installed properly, and not damaged by sector shaft.

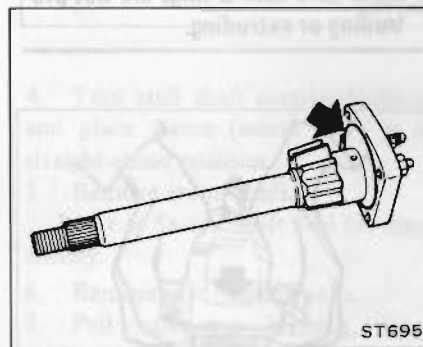

4. Set piston rack at straight-ahead position.

Turn piston rack about 10° to 15° toward yourself with your finger.

This is for smooth insertion of sector gear.

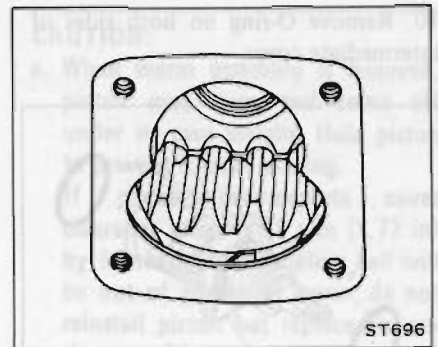

5. Wrap vinyl tape around serration area of sector shaft.

The reason is that vinyl tape prevents oil seal lip from being damaged during insertion.

6. Gradually insert sector shaft into gear housing, being careful not to damage oil seal.

When inserting sector shaft into gear housing, remove plastic film. Be careful not to drop bearings into gear housing.

7. Tighten sector shaft cover bolts.

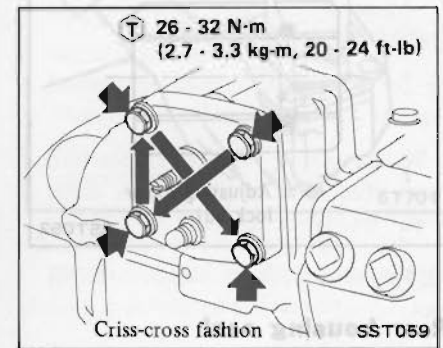

8. Check turning torque and steering gear preload.

Refer to Inspection and Adjustment.

- If there is a great difference between values of turning torque before and after disassembly, it must be assumed that some new problem has occurred. It will be necessary to replace the entire assembly.

STEERING LINKAGE (Equipped with I.P.S. 56L)

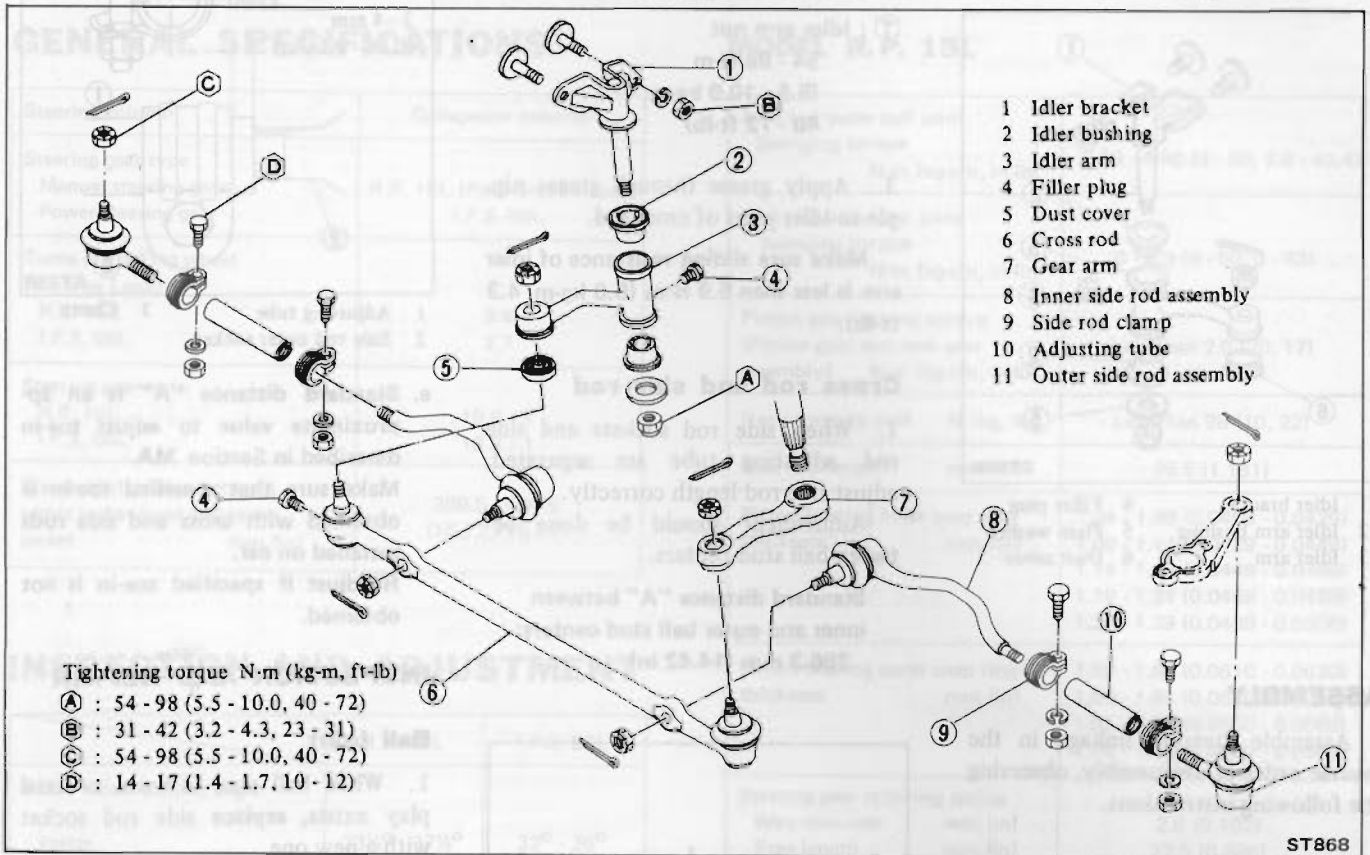

REMOVAL AND INSTALLATION

1. Jack up the front of car and support it on the safety stands.
2. Block rear wheels with chocks.
3. Remove gear arm using Steering Gear Arm Puller ST29020001.

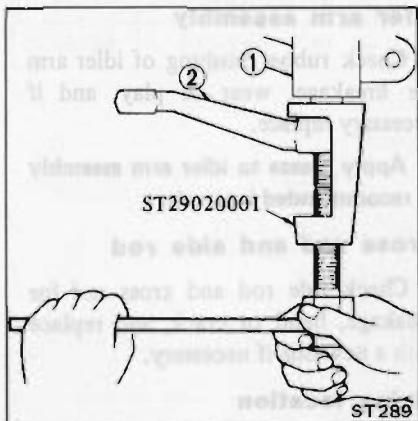

4. Remove idler assembly.
5. To detach side rod ball studs from knuckle arms, insert Steering Ball

Joint Remover HT72520000 between them and separate them.

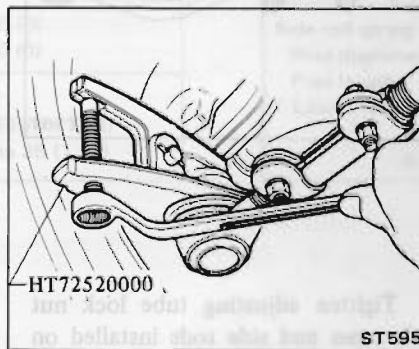

6. Install steering linkage in the reverse order of removal.

⊕ : Ball stud
 54 - 98 N·m
 (5.5 - 10.0 kg·m,
 40 - 72 ft·lb)

Idler arm to body side frame
 31 - 42 N·m
 (3.2 - 4.3 kg·m,
 23 - 31 ft·lb)

7. Check wheel alignment, and if necessary adjust. Refer to Section FA.

DISASSEMBLY

1. Remove both side rod, gear arm and idler arm from cross rod with Steering Ball Joint Remover HT72520000.
2. (1) Side rod
 Loosen adjusting tube clamp, and remove outer and inner side rod sockets from adjusting tube.

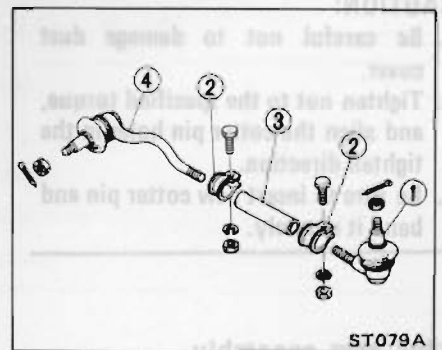

- 1 Outer side rod assembly
- 2 Side rod clamp
- 3 Side rod adjusting tube
- 4 Inner side rod assembly

(2) Idler arm

Loosen nut, and separate parts one after another.

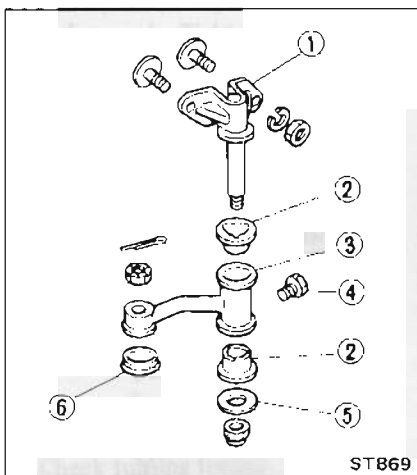

- 1 Idler bracket
- 2 Idler arm bushing
- 3 Idler arm
- 4 Filler plug
- 5 Plain washer
- 6 Dust cover

2. Fit bushing into idler body, and insert shaft of idler arm bracket carefully until bushing protrudes.

- ⊕ : Idler arm nut
 54 - 98 N·m
 (5.5 - 10.0 kg-m,
 40 - 72 ft-lb)

3. Apply grease through grease nipple to idler joint of cross rod.

Make sure sliding resistance of idler arm is less than 5.9 N·m (0.6 kg-m, 4.3 ft-lb).

Cross rod and side rod

1. When side rod sockets and side rod adjusting tube are separated, adjust side rod length correctly.

Adjustment should be done between ball stud centers.

Standard distance "A" between inner and outer ball stud centers:
 366.3 mm (14.42 in)

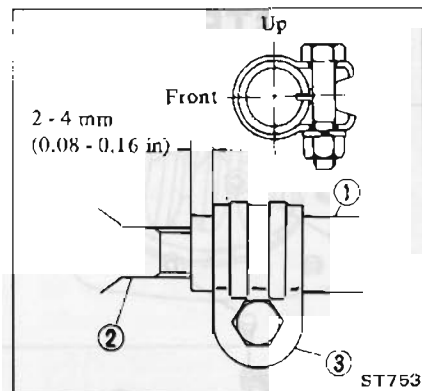
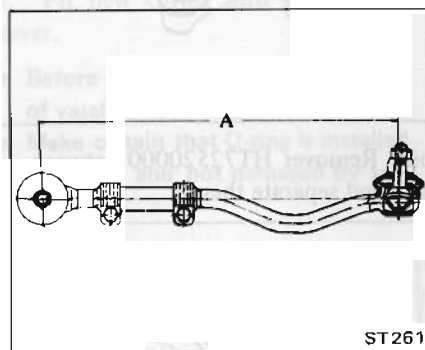

- 1 Adjusting tube
- 2 Side rod outer socket
- 3 Clamp

e. Standard distance "A" is an approximate value to adjust toe-in described in Section MA.

Make sure that specified toe-in is obtained with cross and side rods installed on car.

Readjust if specified toe-in is not obtained.

ASSEMBLY

Assemble steering linkage in the reverse order of disassembly, observing the following instructions.

Ball joint

- ⊕ : Ball stud
 54 - 98 N·m
 (5.5 - 10.0 kg-m,
 40 - 72 ft-lb)

Observe the following during ball joint assembly.

CAUTION:

- a. Be careful not to damage dust cover.
- b. Tighten nut to the specified torque, and align the cotter pin holes in the tighten direction.
- c. Be sure to insert new cotter pin and bend it securely.

Idler arm assembly

To assemble idler arm, proceed as follows:

- 1. Apply coat of multi-purpose grease to bushing.

2. Tighten adjusting tube lock nut with cross and side rods installed on car.

- a. Lock adjusting tube lock nut so that ball joint on outer socket (knuckle arm side) is 90° with respect to that on inner socket (cross rod side).
- b. Be sure to engage inner and outer sockets at least 35 mm (1.38 in) with adjusting tube.
- c. Make sure that clamp faces in direction shown in following figure.
- d. Also make sure that clamp is held within 2 to 4 mm (0.08 to 0.16 in) from end of adjusting tube.

INSPECTION AND REPAIR

Ball joint

- 1. When ball stud is worn or axial play exists, replace side rod socket with a new one.
- 2. When dust cover is broken or deformed, be sure to replace with a new one (rod assembly).

Initial swinging torque:

- Ball joint
 0.49 - 1.47 N·m
 (5 - 15 kg-cm,
 4.3 - 13.0 ft-lb)

Idler arm assembly

Check rubber bushing of idler arm for breakage, wear or play, and if necessary replace.

Apply grease to idler arm assembly at recommended intervals.

Cross rod and side rod

Check side rod and cross rod for breakage, bend or crack, and replace with a new one if necessary.

Fixing location

Check fixing location (nuts and cotter pins) for looseness, play or breakage. When looseness or play is found, check for wear on tapered portion of ball stud, gear arm or idler arm.

SERVICE DATA AND SPECIFICATIONS

GENERAL SPECIFICATIONS

Steering column	Collapsible column
Steering gear type	
Manual steering gear	R.P. 15L (Rack-and-pinion)
Power steering gear	I.P.S. 56L
Turns of steering wheel (Lock to Lock)	
R.P. 15L	3.5
I.P.S. 56L	2.7
Steering gear ratio	
R.P. 15L	19.6 : 1
I.P.S. 56L	16.3 : 1
Standard clearance between upper jacket head and lower jacket	399.5 - 400.5 (15.73 - 15.77)
	mm (in)

INSPECTION AND ADJUSTMENT

	R.P. 15L	I.P.S. 56L
Front wheel turning angle		
degree		
Inside	33½° - 37½°	32° - 36°
Outside	29° - 33°	24½° - 28½°
Steering wheel axial play		
mm (in)		
Equipped with R.P. 15L	0 (0)	
Equipped with I.P.S. 56L	0 (0)	
Steering wheel play		
mm (in)		
Equipped with R.P. 15L	20 - 30 (0.79 - 1.18)	
Equipped with I.P.S. 56L	Less than 35 (1.38)	

MODEL R. P. 15L

Side rod outer ball joint		
Swinging torque		0.29 - 4.90 (3 - 50, 2.6 - 43.4)
N·m (kg-cm, in-lb)		
Side rod inner ball joint		
Swinging torque		0 - 4.9 (0 - 50, 0 - 43)
N·m (kg-cm, in-lb)		
Pinion gear turning torque (Pinion gear and rack gear assembly)	N·m (kg-cm, in-lb)	Less than 2.0 (20, 17)
Rack force to pull	N (kg, lb)	Less than 98 (10, 22)
Side rod length	mm (in)	29.5 (1.161)
Pinion bearing inner snap ring thickness	mm (in)	1.04 - 1.09 (0.0409 - 0.0429) 1.09 - 1.14 (0.0429 - 0.0449) 1.14 - 1.19 (0.0449 - 0.0469) 1.19 - 1.24 (0.0469 - 0.0488) 1.24 - 1.29 (0.0488 - 0.0508)
Pinion bearing outer snap ring thickness	mm (in)	1.55 - 1.60 (0.0610 - 0.0630) 1.60 - 1.65 (0.0630 - 0.0650) 1.65 - 1.70 (0.0650 - 0.0669) 1.70 - 1.75 (0.0669 - 0.0689)
Steering gear retaining spring		
Wire diameter	mm (in)	2.6 (0.102)
Free length	mm (in)	22.5 (0.886)
Load x Length	N x mm (kg x mm, lb x in)	121.6 x 16.3 (12.4 x 16.3, 27.3 x 0.642)
Side rod spring		
Wire diameter	mm (in)	2.6 (0.102)
Free length	mm (in)	19.0 (0.748)
Load x length	N x mm (kg x mm, lb x in)	392 x 17.0 (40 x 17.0, 88 x 0.669)

MODEL I.P.S. 56L

Oil pump belt deflection mm (in)	8 - 12 (0.31 - 0.47) at 98 N (10 kg, 22 lb)
Steering wheel turning torque (at circumference of steering wheel) N (kg, lb)	25 - 29 (2.5 - 3.0, 5.5 - 6.6)
Oil pump pressure kPa (kg/cm ² , psi)	6,571 - 7,748 (67 - 79, 953 - 1,123) at idling
Backlash adjustment Turning torque <ul style="list-style-type: none"> Center (As compared with steering wheel turned 360°) N·m (kg-cm, in-lb) 	0.10 - 0.39 (1 - 4, 0.9 - 3.5) higher
<ul style="list-style-type: none"> 360° (When steering gear assembly alone is turned) N·m (kg-cm, in-lb) 	Less than 1.2 (12, 10)
Ball joint initial swinging torque N·m (kg-cm, in-lb)	0.49 - 1.47 (5 - 15, 4.3 - 13.0)
Standard side rod length mm (in)	366.3 (14.42)

TIGHTENING TORQUE

STEERING COLUMN

Unit	N·m	kg-m	ft-lb
Steering wheel nut	39 - 49	4.0 - 5.0	29 - 36
Jacket tube bracket and cover to dash panel	3.4 - 4.4	0.35 - 0.45	2.5 - 3.3
Steering column mounting bracket	13 - 18	1.3 - 1.8	9 - 13
Coupling to column shaft	16 - 22	1.6 - 2.2	12 - 16
Lower joint to rubber coupling (R.P. 15L)	23 - 26	2.3 - 2.7	17 - 20
Lower joint to pinion gear (R.P. 15L)	39 - 49	4.0 - 5.0	29 - 36
Stub shaft to coupling (I.P.S.)	32 - 38	3.3 - 3.9	24 - 28

STEERING GEAR AND LINKAGE

Model R.P. 15L

Unit	N·m	kg-m	ft-lb
Side rod to knuckle arm	54 - 98	5.5 - 10.0	40 - 72
Side rod lock nut	78 - 98	8.0 - 10.0	58 - 72
Gear housing clamp	45 - 60	4.6 - 6.1	33 - 44
Retainer lock nut	39 - 59	4.0 - 6.0	29 - 43
Side rod inner socket lock nut	78 - 98	8.0 - 10.0	58 - 72

Model I.P.S. 56L

Unit	N·m	kg-m	ft-lb
Oil pump to bracket	19 - 25	1.9 - 2.6	14 - 19
Gear arm nut	127 - 147	13 - 15	94 - 108
Steering gear housing to body	52 - 62	5.3 - 6.3	38 - 46
Sector shaft adjusting screw lock nut	28 - 34	2.9 - 3.5	21 - 25
Hose to oil pump	29 - 49	3.0 - 5.0	22 - 36
Bleeder screw	6.9 - 8.8	0.7 - 0.9	5.1 - 6.5
Sector shaft cover bolt	26 - 32	2.7 - 3.3	20 - 24
Rear housing bolt	26 - 32	2.7 - 3.3	20 - 24
Idler body to frame	31 - 42	3.2 - 4.3	23 - 31
Ball stud nuts	54 - 98	5.5 - 10.0	40 - 72
Side rod adjusting tube clamp nuts	14 - 17	1.4 - 1.7	10 - 12
Idler arm nut	54 - 98	5.5 - 10.0	40 - 72
Hose to gear housing	49 - 69	5.0 - 7.0	36 - 51

b. Tighten nut to the specified torque, and align the center pin holes in the opposite direction.

c. Be sure to insert the center pin and bend it evenly.

Install lower assembly

To assemble this unit, proceed as follows:

1. Apply coat of anti-rust grease to housing.

a. Lock steering side ball nut to that ball joint by using socket wrench and hold it 90° with respect to that side lower control arm rod shaft.

b. Be sure to engage lower and upper sockets at about 90° and adjust ball with adjusting tube.

1. Make sure that steering lower in direction shown in following figure.
2. Also make sure that steering is held within 2 to 4 mm (0.08 to 0.16 in) from end of adjusting tube.

Apply grease to idler arm assembly at recommended intervals.

Cross rod end side rod.

Check side rod end cross rod for looseness, bend or crack, and adjust with a nut and if necessary.

Fixing tie-rods

Check idler bearing (lower) and make sure that the looseness, play or leakage, from bottom or plug is found, check the wear for broken portion of ball nut, gear arm or idler arm.

TROUBLE DIAGNOSES AND CORRECTIONS



MANUAL STEERING

Refer to TROUBLE DIAGNOSES AND CORRECTIONS in “Front Axle & Front Suspension” Section.

POWER STEERING

Condition	Probable cause	Corrective action
Oil pressure does not build up.	Pump drive belt slipping on pulley. Pump malfunctioning. Oil leaking through hose joints. Oil leaking through power steering.	Readjust belt tension. Replace. Replace or retighten copper washer. Replace sealing parts at steering gear.
Steering wheel moves heavily.	Lack of oil in oil pump.* Air present in oil. Oil pressure too low. Wheel alignment out of specifications or air pressure in tires too low.* Steering gears improperly engaged.* Steering column out of alignment.* Worn or damaged ball joint at suspension and steering linkage.* Idler arm dragging.*	Refill. Bleed air. See “Hydraulic system check”. Re-align or inflate tires to correct pressure. Replace gear assembly. Repair or replace. Replace. Repair or replace.
Steering wheel fails to return.	Refer to items marked “*” above. Front wheel caster improperly adjusted. Internal gears dragged or gouged.	Readjust. Replace gear assembly.
Steering effort is not the same in both directions.	Oil leakage in steering gear. Stuffy oil passage in steering gear.	Replace sealing parts. Replace gear assembly.
Unstable running.	Wheel bearing not properly adjusted. Stuck or damaged control valve in steering gear. Front wheel alignment not properly. Excessive steering gear play. Play at suspension and linkage ball joint.	Readjust. Replace gear assembly. Readjust. Readjust backlash or replace gear assembly. Replace.
Noisy pump.	Lack of oil in oil pump. Hoses or oil filter clogged. Loose pulley. Belt noisy or slapping. Broken pump part.	Refill. Clean or, if necessary, replace. Repair. Readjust tension. Replace.

SPECIAL SERVICE TOOLS

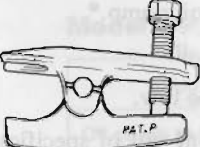
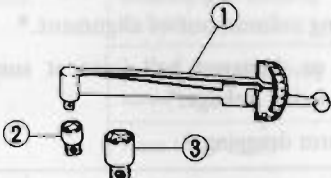
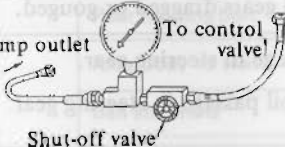
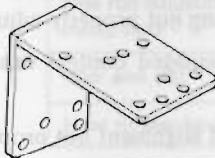
Tool number (Kent-Moore No.)	Tool name	
ST29020001 (J 25725)	Steering gear arm puller	
ST27180001 (J 25726)	Steering wheel puller	
HT72520000 (-)	Steering ball joint remover	
ST3127S000 (See J 25765) ① GG91030000 (See J 25765) ② HT62900000 (-) ③ HT62940000 (-)	Preload gauge Torque wrench Socket adapter Socket adapter	
ST27091000 (-)	Pressure gauge	 To oil pump outlet To control valve Shut-off valve
KV48100301 (J 25729)	Steering gear housing attachment	
KV481009S0 (J 26367) ① KV48100910 (-) ② KV48100920 (-) ③ KV48100930 (-)	Oil seal drift set Drift Adapter Adapter	